



STEADYMIG500

STEP CONTROL MIG WELDER

OPERATING INSTRUCTIONS



DIRECT
CURRENT



LCD
SCREEN



400V 50HZ
THREE
PHASE



INTELLIGENT
PROTECTION
SYSTEM



SPIKE/
GENERATOR
SAFE



CORROSION
RESISTANT



STEADYMIG500

Congratulations on your new Strata product!

The Strata range from Euroquip uses latest technology design and engineering to produce welding products that combine market leading value and features with durability. Designed for discerning operators who seek professional results and product quality without the price tag of a full professional setup. Design emphasis is placed on simple, functional design and operation. Strata product is subject to stringent quality control and designed and manufactured to NZ & Australian standards.

Common use of Strata products include:

- Light Engineering
- Automotive
- Home/Hobby Engineering
- Farming
- Industrial Maintenance & Repairs

For industrial welding solutions, check out the Strata range from Euroquip:

www.strata.co.nz

Euroquip is a market leading provider of innovative power equipment solutions to a wide range of industries across New Zealand and Australia. Key product categories are; welding equipment, air compressors, power generators and cleaning equipment.

Euroquip's slogan is 'empowering industries', find out more about the advantage Euroquip brings at **www.euroquip.co.nz**.



STRATA

SUPERIOR WELDING PRODUCTS

500A

STEADYMIG500

500A
Max Output

32A 400V
THREE-PHASE



500A Industrial Three-Phase Transformer MIG Welder



The STEADYMIG 500, part of STRATA's flagship MIG range, is engineered for New Zealand's toughest conditions. Designed in collaboration with leading engineering firms, it delivers unmatched performance in heavy fabrication. Its 'super duty' copper wound three-phase transformer achieves a market-leading 350A @ 100% duty cycle, offering smooth welding and reliability. The machine features 30 precise adjustment levels for perfect welds, a heavy duty full chassis trolley for easy mobility and accommodation of a full height gas cylinder, and a fully enclosed 4 roller wire feeder that enhances consistency and shields against dust and moisture. With a swivel system and 10m interconnection lead and a 4m MB36 welding torch, the STEADYMIG 500 ensures superior welding performance no matter the accessibility or size of job, making it the top choice for demanding MIG welding tasks.

- ✓ 4wd Separate wire feeder with digital control provides stable wire feed and user friendly adjustments.
- ✓ 10m wire feeder interconnecting cable for easy access to any area of the worksite
- ✓ Super Duty Copper wound transformer and smoothing choke
- ✓ Large 300mm Forced air fan cooling
- ✓ Digital volt and amp meter
- ✓ Thermal Overload warning indicator
- ✓ Heavy duty front and rear wheels
- ✓ All geared 4-roll metal cast feed system
- ✓ Support strap for gas cylinder
- ✓ Digital Infinitely variable wire speed
- ✓ 2 step/4step latching capability
- ✓ Burnback control
- ✓ Gas purge function
- ✓ Wire Inching button
- ✓ Accessories include: Argon regulator, MB36 Mig torch and cable hangers, H/D 5m Earth lead & clamp, 32A three phase plug

Description	Details
DIMENSIONS (LxWxH)	875 x 490 x 775mm
WEIGHT	200kg
INPUT POWER SUPPLY	400V AC 50Hz 3 Phase
MAXIMUM INPUT CURRENT	44A
GENERATOR CAPACITY	29kVA
MIG OUTPUT VOLTAGE	39V
MIG CURRENT OUTPUT	50-500A
MIG DUTY CYCLE	500A @ 50% 460A @ 60% 350A @ 100%

Description	Details
VOLTAGE SETTINGS	30
LIFT TIG CURRENT OUTPUT	10-160A
INSULATION CLASS	IP21S
POWER EFFICIENCY	I Eff = 31A
STANDARDS	IEC/AS 60974-1
WARRANTY	48 Months

Includes:



STEADYMIG500
User guide, specs, videos

LEARN MORE



STEADYMIG500

Contents

1. Description Of Controls.....	5
2. Installation Of Welder.....	7
3. Welding.....	8
4. Welding Defects.....	9
5. Care & Maintenance.....	10
6. Safety.....	12
7. Troubleshooting.....	16
8. Welder Parts List.....	17
9. Wire Feeder Parts List.....	18
10. Warranty.....	19

This manual has been prepared with the intent of instructing the operator on how to install, operate, and properly maintain this electric arc welding machine and the wire feeder.

This machine is a constant voltage power source for MIG/MAG welding.

Upon receiving and unpacking the machine, make a careful inspection to ensure that there are no damaged parts.

Should there be a claim for losses or damages it must be made by the purchaser directly to the shipper who handled the goods. When requesting information about this welding machine please state the machine's part number and serial number to ensure receiving accurate information relating to your machine.



STEADYMIG500

1. Description Of Controls

1.1 Controls On Generator Front Panel

- A: Rotary weld voltage switch:
This switch adjusts the weld voltage range.
- B: Rotary weld voltage switch:
This switch allows the fine tuning of the welding voltage selected with switch G. (Step adjustment)
Some model without the function.
- C: Voltmeter
- D: Ammeter
- E: Power switch
- F: Quick connector for work return lead
(some model the quantity is different)

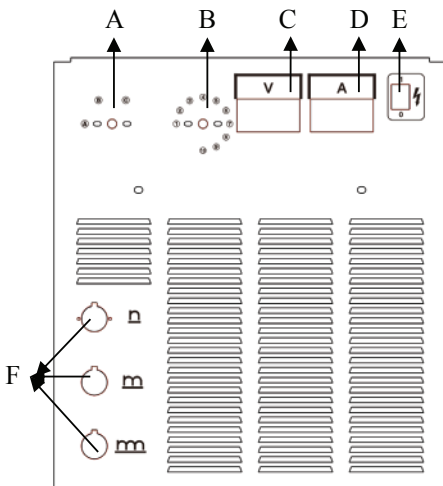

1.2 Controls On Generator Rear Panel

- A: Power fuse
- B: Support for cylinder
- C: Input power cable
(Confirm the power voltage before use)
- E: Socket for heater of regulator
- G: Welding Output connector

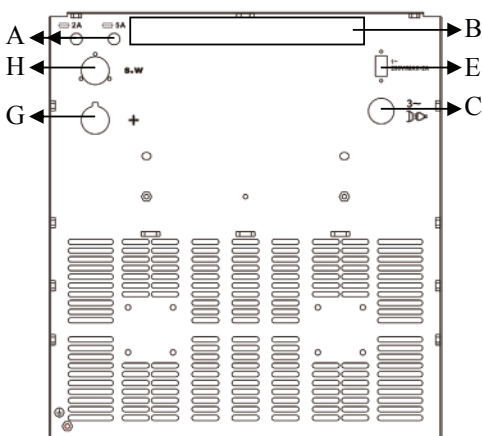

1.3 Controls On The Wire Feeder Front Panel

- A- Quick connect torch terminal
The welding torch is attached to this terminal.
- B- Digital control description
- C- Quick-fit hose connectors for connection to water hoses of water-cooled torches.
Important: These connectors are colour-coded for safety.
Ensure that hose and connector colours match.

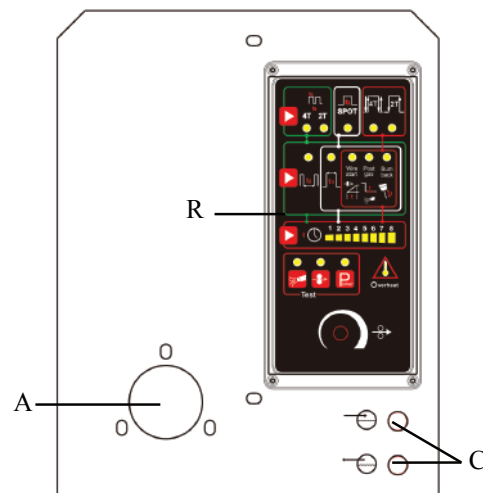

1.4 Controls On The Wire Feeder Rear Panel

- L-Gas hose fitting for extension gas hoses.
- M - 6-pin socket connector for 6-pin plug connector
- N-Socket for extension power supply plug.
- O - Quick-fit hose connectors for connection to extension water hoses.
Important: These connectors are colour-coded for safety.
Ensure that hose and connector colours match.

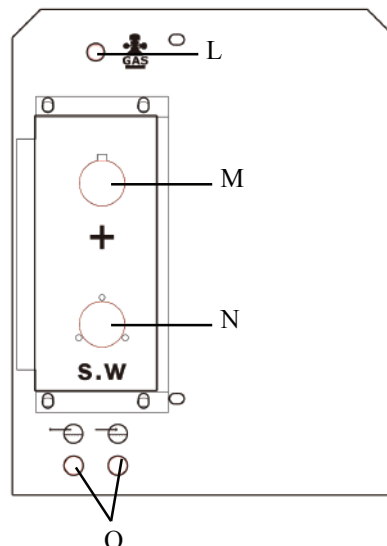

1.5 Digital Control description

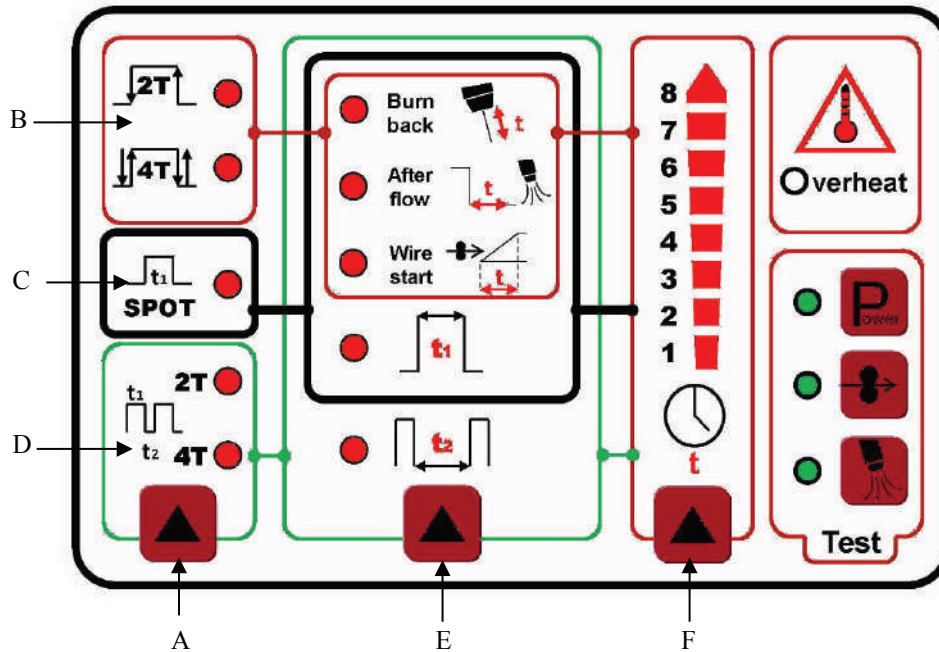

A---Trigger Function Selection: Three modes to select

B---Normal welding mode : ---normal welding 2T mode (non-latching)

C---Spot welding mode : ---normal welding 4Tmode (latching)

D---Stitch welding mode : **2T** ○ ---Stitch welding 2Tmode
4T ○ ---Stitch welding 4Tmode

E---Parameter setting

Please note the wire frame on the panel:

RED frame for normal MIG welding modes

BLACK frame for Spot welding modes

GREEN frame for Stitch welding modes

---burn back, ---gas after flow, ---wire start

t1---Welding time for “spot” or “stitch ON” operation.

t2---Welding time for “stitch OFF” operation.

F---Welding time setting

The higher the number, the longer the time for function selected.

---Overheat warning. Machine will auto-reset after cooling period and light will go off.

---Power test. Confirms machine is wired correctly to line power supply.

---Fast wire feeding test. Confirms wire feed motor is functional and used for set-up.

---Gas test. Confirms shield gas input system is functional.



STEADYMIG500

2. Installation Of Welder

2.1 Setup

Place the machine in a ventilated area. Dust, dirt, or any other foreign material that might enter the machine may restrict the ventilation which could affect the machine's performance. Fasten the rotating support to the machine top and fix the handle, the wheels, the bottle support and, if any, the cooling unit.

2.2 Input Power Connections

All sections concerning the installation of this machine must be read carefully. This machine must be installed by skilled personnel. Make sure that the input power plug has been disconnected before inspecting, maintaining, or servicing. Connect the yellow-green wire to a good electrical ground.

Do not use water pipes as earth conductor. After a final inspection, the machine should be connected to the input supply voltage marked on the input power cord. If you wish to change the input supply voltage, remove the right side panel, locate the voltage-changing terminal board and arrange the connections as shown in ILLUSTRATION OF WORKING PRINCIPLE.

After having changed the supply voltage, re-place the upper cover. This machine must never be used without the top and side covers. This is both for obvious safety reasons and to avoid interference with the machine's internal cooling system. The warranty is to be considered null and void if this machine is used without the protection of its top and side covers. Mount a plug on the power supply cable that corresponds to the input power drawn by the machine.

2.3 Output Connections



2.3.1 Wire feeder connection

This power source is compatible with the wire feeders. To connect the power source to the wire feeder units use the extension art. Only skilled personnel should install the machine. All connections must be carried out according to current regulations, and in full observance of safety laws. Information on installation and setup of wire feeder below.

2.3.1.1 Wire Feeder Placement

Unpack the wire feeder and place it above the welding machine, using the flexible rotating cylinder provided (optional).

2.3.2 Connecting the work return lead clamp

Some versions have one impedance socket only. Connect the male end of the work return lead to one of the impedance taps on the front panel of the machine. The impedance tap  designated by the provides the maximum amount of impedance which will produce nicely filleted weld beads. This tap is recommended when welding aluminium, stainless steel, and carbon steels of binary or ternary composition. The impedance tap  designated by the provides the least amount of impedance and is recommended when using carbon dioxide as a shielding gas to weld carbon steels, in the upwards vertical position, of binary or ternary composition. It is generally advisable to use low impedance values for small diameter wires and high values for big diameter wires. After having selected the proper impedance tap, attach the work return clamp to the work to be welded. Make sure that the ground clamp is tightly fastened to the work return cable and periodically check that this connection remains well tightened. A loose connection can cause weld current drops or overheating of the work return lead and clamp which, in turn, creates the risk of burns from accidental contact with the work return lead. The weld circuit must not be placed deliberately in direct or indirect contact with the ground conductor if it is not in the work to be welded. If the work to be welded is attached deliberately to the ground by a protection lead, then the connection must be the most direct possible and it must be done using a lead that has a cross section that is at least equal to the cross section of the work return lead being used for the weld circuit. The protection lead must also be attached to the work at the same spot as the work return lead. To do so, a second ground clamp, fitted to the protection lead, must be attached next to the ground clamp of the work return lead.

2.3.3 Connecting the gas hose

Keep the cylinders in an upright position by chaining them to their support. Keep the cylinders in a place where they cannot be damaged. Do not lift the machine with the cylinder on its support. Keep the cylinder away from the welding area and uninsulated electric circuits. Cylinders containing inert gas have to be equipped with a pressure reducer and a flowmeter. After having positioned the cylinder, connect the gas hose that comes out from the rear of machine to the pressure reducer output. Regulate the gas flow to 8-10 L/min.



3. Welding

3.1 Installation And Starter

Machine installation must be done by a competent staff. All connections must correspond to the rules in force and must respect laws concerning accidents. Check that the wire diameter corresponds to that indicated on the roll and mount the wire coil. Connect the pipe coming out of the extension with the cylinder flowmeter. Position the welding machine so as to allow free air circulation inside it and avoid that metal or any other.

3.2 The Machine Is Ready To Weld

Connect the ground terminal to the part to be welded. Turn the machine on. Extract the conic gas nozzle by rotating it clockwise. Unscrew the current nozzle. Press the torch trigger to feed the wire until it comes out from the torch.



WARNING: *Keep your face away from the terminal nozzle while the wire comes out.*

Screw the current nozzle again, making sure that the hole diameter be the same as that the wire used. Insert the welding conic gas nozzle by rotating it clockwise. Open the gas cylinder and adjust flowmeter at 8-10L/min.



WARNING: *Check that the gas used is compatible with the material to be welded.*

3.3 Welding Carbon Steels

To weld carbon steels the following things are necessary:

1) The use of a binary shielding gas which is most commonly Argon and Carbon dioxide, in a ratio of 75-80 % Argon and 25-20% Carbon dioxide. Some applications, however, may require a mix of three gases: Argon, Carbon dioxide (CO₂), and dioxide (O₂). These gas mixtures generate heat during welding and as a result the weld bead will be well filleted and neat in appearance. The penetration, however, will not be deep.

The use of Carbon dioxide as the shield gas results in a narrow weld bead with deep penetration but the ionization of the gas will have an influence on arc stability.

2) The use of a filler wire of the same quality as the steel to be welded. It is recommended that high quality wires be used and that welding with rusted wires be avoided because they can give rise to defects in the weld bead. Generally, the current range within which a wire can be used is calculated in the following manner:

\emptyset of wire x 100= minimum number of Amperes.

\emptyset of wire x 200= maximum number of Amperes.

Practical example: 1.20 \emptyset wire= 120 Amps minimum and 240 Amps maximum. These amperages are based on the use of an Argon/CO₂mixture as the shield gas and welding in the Short Arc transfer mode.

3) Avoid welding on rusted work pieces or work having spots of oil and grease present on the surface.

4) The use of a welding torch suitable to the welding currents that are going to be used.

5) Periodically check that the two handles making up the ground clamp are not damaged and that the welding cables (torch cable and the work return lead) do not have any cuts or burn marks that would reduce their efficiency.

3.4 Welding Stainless Steel

Welding stainless steels in the 300 series (the austenitic series) must be done using a shield gas mixture of predominantly Argon with a small percentage of O₂ added to stabilize the arc. The recommended mixture is AR/O₂ in the ratio of 98/2. Do not use CO₂ or AR/CO₂mixtures as the shield gas. Do not touch the welding wire with your bare hands. The filler metal (the wire) must be of a higher quality than the work to be welded and the weld area must be clean.



STEADYMIG500

3.5 Welding Aluminium

The following is required for aluminium welding:

- 1) 100% Argon as welding protection gas.
- 2) A torch wire of composition suitable for the basic material to be welded.

For ALUMAN welding wire 3.5% silicon.

For ANTICORODAL welding wire 3.5% silicon.

For PERALUMAN welding wire 5% magnesium.

For ERGAL welding wire 5% magnesium.

- 3) A torch prepared for aluminium welding.

If you only have a torch for steel wires, the same shall be modified in the following way:

- Make sure that length of torch cable does not exceed 118 inches (it is advisable not to use longer torches).
- Remove the brass sheath-holding nut, the gas and the current nozzles, then slip the sheath off.
- Insert the teflon sheath for aluminium and ensure it protrudes from both ends.
- Screw the current nozzle so that the sheath adheres to it.
- Insert the sheath holding nipple, the O-Ring in the free end of the sheath and secure with the nut without tightening too much.
- Slip the brass tube on the sheath and insert both into the adaptor (after removing the iron tube which was fitted inside the adaptor).
- Cut the sheath diagonally so that it stays as close as possible to the wire slide roller.

- 4) Use drive rolls that are suitable for aluminium wire. The drive rolls, when being installed, must be tightened as tight as possible.

- 5) Use contact tips that are suitable for aluminium wire and make sure that the diameter of the contact tip hole corresponds to the wire diameter that is going to be used.

- 6) Use abrasive grinders and tool brushes specifically designed for aluminium. Never use these tools on other materials. **REMEMBER that cleanliness equals quality.**

The wire spools must be stored in plastic bags with a dehumidifier.

4. Welding Defects

- 1- DEFECT- **Porosity** (in, or on the surface of the weld bead)

CAUSES Bad wire (rust on the surface).

Insufficient gas shielding due to:

- Inadequate gas flow due to a block in the gas line.
- Defective flowmeter.
- Gas regulator covered with frost because a gas heater was not used to heat the CO₂ shielding gas.
- Failure of gas valve solenoid.
- Gas nozzle plugged up with spatter.
- Gas flow holes plugged up.
- Air drafts in the welding area.

- 2- DEFECT- **Shrinkage Cracks**

CAUSES Welding wire or work to be welded dirty or rusty.

Weld bead too small.

Weld bead too concave.

Too much weld bead penetration.

- 3- DEFECT- **Lateral cracking**

CAUSES Welding speed too fast.

- 4- DEFECT- **Too much Spatter**

CAUSES Voltage too high

Insufficient impedance

No gas heater used for CO₂ shielding gas.



5. Care & Maintenance

5.1 Tips for Keeping your Welding Machine in Top Condition

Here is a list of general maintenance that should be adhered to on any welder. For more specific maintenance care of this machine, see page 12.

- Regularly clean the ventilation slots.
- Keep the casing clean.
- Check all cables before use.
- Check electrode holders, work lead/clamps and welding torches before use.
- Replace worn electrode holders and earth clamps, which do not provide a good connection.
- Replace worn consumable parts in a timely manner.
- Use a soft cloth or brush to clean electrical components.
- Do not use liquid cleaning products, water or especially solvents.
- Do not use compressed air to clean electrical components as this can force dirt and dust further into components, causing electrical short circuits.
- Check for damaged parts. Do not use the welder with damaged parts.
- A damaged welder must be carefully checked by a qualified person to determine that it will operate properly. Check for breakage of parts, mountings and other conditions that may affect its operation. An authorised service centre should properly repair a damaged part. Have your welder repaired by an expert.

This appliance is manufactured in accordance with relevant safety standards. Only experts must carry out repairing of electrical appliances, otherwise considerable danger for the user may result. Use only genuine replacement part. Do not use modified or non-genuine parts.

5.2 Storing the Welder

When not in use the welder should be stored in the dry and frost-free environment.



WARNING! Before performing cleaning/maintenance, replacing cables / connections, make sure the welding machine is switched off and disconnected from the power supply.



STEADYMIG500

5.3 Machine Maintenance

Gas nozzle. Periodically clean the nozzle of all weld spatter that may have accumulated during welding operations. If the nozzle should become distorted or oval in shape then it must be replaced.

Contact tip. A good contact between the contact tip and the wire ensures a stable arc and optimal current output. Therefore, following steps must be followed:

- A) The contact tip hole must be kept free of dirt or oxidation.
- B) After lengthy welds, spatter can easily accumulate on the contact tip and prevent the wire from being fed. The contact tip must be cleaned regularly and if necessary it must be replaced.
- C) The contact tip must always be screwed tightly on to the body of the torch. The thermal cycles which the torch undergoes during operation may loosen the contact tip which, in turn, may cause the torch body and nozzle to overheat or cause unsteady wire feed.

The Wire Liner is an important part that must often be checked since, during normal operations, the wire can deposit copper dust or tiny metal shavings in the lining. Periodically clean the liner and the gas line with a jet of dry, compressed air. Wire liners are exposed to continual wear and therefore they must be replaced after a certain period of time.

Wire feed motor. Periodically clean the wire feed assembly and the drive rolls from any rust or metal shavings due to the feeding of the wire. A periodic check of all the components of the wire feed assembly, spool holder, drive rolls, wire liner and the contact tip is recommended.

5.4 Welding Machine Servicing

Experience has shown that many fatal accidents originated from servicing improperly executed. For this reason, a careful and thorough inspection on a serviced welding machine is just as important as one carried out on a new welding machine. Furthermore, in this way producers can be protected from being held responsible for defects stemming from repairs not carried out by the manufacturer.

5.5 Prescriptions to follow for servicing

After rewinding the transformer or the inductance, the welding machine must pass the applied-voltage test in accordance with indications of the international standard. If the servicing is not done by the manufacturers, the repaired welding machines which underwent replacements or modifications of any component shall be marked in a way such that the identity of the person having serviced it is clear. After making repairs, take care to re-order the cables so that there is sure to be insulation between the primary and secondary sides of the machine. Make sure that the wires cannot come into contact with moving parts or parts that heat during operation. Replace all clamps in their original positions on the machine, to prevent a connection between the primary and secondary circuits if a conductor accidentally breaks or disconnects.



6. Safety

Store and Retain this Manual

Retain this manual for the safety warnings and precautions, assembly, operating, inspection, maintenance and cleaning procedures. Write the product serial number at the rear of this manual and keep this manual and the receipt in a safe and dry place for future reference.

Important Safety Information

Failure to follow the warnings and instructions may result in electric shock, fire, serious injury and/or death. Save all warnings and instructions for future reference.



This is the safety alert symbol to alert you to potential personal injury hazards. Obey all safety messages that follow this symbol to avoid possible injury or death.



DANGER! indicates a hazardous situation which, if not avoided, will result in death or serious injury.



WARNING! indicates a hazardous situation which, if not avoided, could result in death or serious injury.



CAUTION, used with the safety alert symbol, indicates a hazardous situation which, if not avoided, could result in minor or moderate injury.

NOTE, used to address practices not related to personal injury.

General Safety Warnings

1. Maintain labels and nameplates on the welder. These carry important information. If unreadable or missing, contact Euroquip for a replacement.

2. Avoid unintentional starting. Make sure the welder is setup correctly and you are prepared to begin work before turning on the welder.

3. Unplug before performing maintenance.

Always unplug the welder from its electrical outlet before performing any inspection, maintenance, or cleaning procedures.

4. Never leave the welder unattended while energised. Turn power off before leaving the welder unattended.

5. Do not touch live electrical parts. Wear dry, insulating gloves. Do not touch the electrode or the conductor tong with bare hands. Do not wear wet or damaged gloves.

6. Protect yourself from electric shock. Do not use the welder outdoors. Insulate yourself from the work piece and the ground. Use non-flammable, dry insulating material if possible, or use dry rubber mats, dry wood or plywood, or other dry insulating material large enough to cover the area of contact with the work or the ground.

7. Avoid inhaling dust. Some dust created by power sanding, sawing, grinding, drilling, cutting, welding and other construction activities, contain chemicals known to cause cancer, birth defects or other harm. Your risk from these exposures varies, depending on how often you do this type of work. To reduce your exposure to these chemicals, work in a well-ventilated area, and work with approved safety equipment, such as dust masks that are specially designed to filter out microscopic particles.

8. People with pacemakers should consult their physician(s) before using this machine.



WARNING!

Electromagnetic fields in close proximity to a heart pacemaker could cause interference, or failure of the pacemaker. The use of a Welder is **NOT RECOMMENDED** for pacemaker wearers. Consult your doctor.



STEADYMIG500

9. Ensure that the unit is placed on a stable location before use.



WARNING!

If this unit falls while plugged in, severe injury, electric shock, or fire may result.

10. Transportation Methods Lift unit with the handles provided, or use a handcart or similar device of adequate capacity. If using a fork lift vehicle, secure the unit to a skid before transporting.



CAUTION!

Disconnect input power conductors from de-energized supply line before moving the welding power source.

11. Exercise good work practices. The warnings, precautions, and instructions discussed in this instruction manual cannot cover all possible conditions and situations that may occur. It must be understood by the operator that common sense and caution are factors which cannot be built into this product, but must be considered by the operator.

Welding Safety Instructions & Warnings



WARNING!

Protect yourself and others from possible serious injury or death. Keep children away. Read the operating/Instruction manual before installing, operating or servicing this equipment. Have all installation, operation, maintenance, and repair work performed by qualified people.

If an operator does not strictly observe all safety rules and take precautionary actions, welding products and welding processes can cause serious injury or death, or damage to other equipment or property. Safe practices have developed from past experience in the use of welding and cutting.

These practices must be learned through study and training before using this equipment. Some of these practices apply to equipment connected to power lines; other practices apply to engine driven equipment. Anyone not having extensive training in welding and cutting practices should not attempt to weld.

Safe practices are outlined in the European Standard EN60974-1 entitled: Safety in welding and allied processes.



WARNING!

Only use safety equipment that has been approved by an appropriate standards agency. Unapproved safety equipment may not provide adequate protection. Eye and breathing protection must be AS/NZS compliant for the specific hazards in the work area.



DANGER!

Always wear AS/NZS compliant safety glasses and full face shield fitted with appropriate filter shade number (Refer Filter Table in this safety section)



CAUTION!

Heavy-duty work gloves, non-skid safety shoes and hearing protection used for appropriate conditions will reduce personal injuries.



CAUTION!

Have the equipment serviced by a qualified repair person using identical replacement parts. This will ensure that the safety of the power tool is maintained.

Personal Safety



CAUTION!

Keep the work area well lit. Make sure there is adequate space surrounding the work area. Always keep the work area free of obstructions, grease, oil, trash, and other debris. Do not use equipment in areas near flammable chemicals, dust, and vapours. Do not use this product in a damp or wet location.

1. Stay alert, watch what you are doing and use common sense when operating equipment. Do not use a tool while you are tired or under the influence of drugs, alcohol or medication. A moment of distraction when operating equipment may result in serious personal injury.
2. Do not overreach. Keep proper footing and balance at all times. This enables better control of the power tool in unexpected situations.



STEADYMIG500

Arc Rays can Burn Eyes and Skin



DANGER!

Arc rays from the welding process produce intense heat and strong ultraviolet rays that can burn eyes and skin.

1. Use a Welding Helmet or Welding Face Shield fitted with a proper shade filter (refer AS 60974-1, AS/NZS 1337.1 and AS/NZS 1338.1 Safety Standards) to protect your face and eyes when welding or watching. (See Filter Table later in this section)
2. Wear approved safety glasses. Side shields are recommended.
3. Use protective screens or barriers to protect others from flash and glare; warn others not to watch the arc.
4. Wear protective clothing made from durable, flame-resistant material (wool and leather) and foot safety protection.
5. Never wear contact lenses while welding.

Noise Can Damage Hearing



CAUTION!

Noise from some processes can damage hearing. Use AS/NZS compliant ear plugs or ear muffs if the noise level is high.

Work Environment Safety



DANGER!

Remove any combustible material from the work area.

1. When possible, move the work to a location well away from combustible materials. If relocation is not possible, protect the combustibles with a cover made of fire resistant material.
2. Remove or make safe all combustible materials for a radius of 10 metres around the work area. Use a fire resistant material to cover or block all doorways, windows, cracks, and other openings.
3. Enclose the work area with portable fire resistant screens. Protect combustible walls, ceilings, floors, etc., from sparks and heat with fire resistant covers.

4. If working on a metal wall, ceiling, etc., prevent ignition of combustibles on the other side by moving the combustibles to a safe location. If relocation of combustibles is not possible, designate someone to serve as a fire watch, equipped with a fire extinguisher, during the welding process and well after the welding is completed.
5. Do not weld or cut on materials having a combustible coating or combustible internal structure, as in walls or ceilings, without an approved method for eliminating the hazard.
6. After welding, make a thorough examination for evidence of fire. Be aware that visible smoke or flame may not be present for some time after the fire has started. Do not weld or cut in atmospheres containing dangerously reactive or flammable gases, vapours, liquids, and dust. Provide adequate ventilation in work areas to prevent accumulation of flammable gases, vapours, and dust.
7. Do not apply heat to a container that has held an unknown substance or a combustible material whose contents, when heated, can produce flammable or explosive vapours. Clean and purge containers before applying heat. Vent closed containers, including castings, before preheating, welding, or cutting.

Electricity Can Kill



DANGER!

Touching live electrical parts can cause fatal shocks or severe burns. The electrode and work circuit is electrically live whenever the output is on.

The input power circuit and machine internal circuits are also live when power is on. In semi-automatic or automatic wire welding, the wire, wire reel, drive roll housing, and all metal parts touching the welding wire are electrically live. Incorrectly installed or improperly grounded equipment is a hazard.

1. Do not touch live electrical parts.
2. Wear dry, hole-free insulating gloves and body protection.
3. Insulate yourself from the work and the ground using dry insulating mats or covers.



STEADYMIG500

4. Disconnect input power before installing or servicing this equipment. Lock input power, disconnect switch open, or remove line fuses so power cannot be turned on accidentally.
5. Properly install and ground this equipment according to national, state, and local codes.
6. Turn off all equipment when not in use. Disconnect power to equipment if it will be left unattended or out of service.
7. Use fully insulated electrode holders. Never dip the holder in water to cool it or lay it down on the ground or the work surface. Do not touch holders connected to two welding machines at the same time or touch other people with the holder or electrode.
8. Do not use worn, damaged, undersized, or poorly spliced cables.
9. Do not wrap cables around your body.
10. Connect work piece to a good electrical ground.
11. Do not touch the electrode while in contact with the work (ground) circuit.



7. Troubleshooting

TROUBLE	PROBABLE CAUSE	REMEDY
Limited electric output	A phase missing	Check the phase of the feed line and/or the remove control switch contacts
	A line fuse is burnt	Replace it
	Wrong connection on the voltage changer terminal board	Check the terminal board connections by following the plate scheme
	The rectifier diode are burnt	Replace the rectifier
	Loosened torch or ground connections	Tighten all connections
	Welding regulation commutator has an uncertain contact	Replace the commutator
	Transformer wire interrupted on the commutator	Unscrew the commutator contact remove the wire insulation and put it under the contact
Welding with a lot of metal spatter	Wrong adjustment of the welding parameters	Select the correct parameters through the welding voltage switch and the wire-speed adjustment potentiometer
	Wire advancing improperly	Uncorrected sheath diam.
	Insufficient grounding	Check grounding connections
Wire not advancing or	Wire roller with too wide groove	Replace roller
advancing improperly	Obstructed or clogged liner	Extract it and clean
	Loose wire pressing roller.	Tighten it
	Coil reel friction too tight	Loosen and adjust it
	Current nozzle clogged	Replace it
The wire jams or entangles between the drive rolls and the torch infeed wire guide	Wrong current nozzle diameter	Replace it
	wrong roller groove alignment	Align it
	Obstructed or clogged sheath	Remove and clean

Note: All repair work must be done by qualified personnel.

Disconnect the power input cable from the mains supply before replacing cables or before removing the unit covers. The machine is equipped with a thermostat that shuts the machine down when the power source overheats. After the thermostat intervenes, let the power source cool down for several minutes before resuming welding operations. The troubleshooting table lists troubles, causes and remedies for those troubles that occur most commonly.



STEADYMIG500

8. Welder Parts List

NO.	Code	Description	NO.	Code	Description
1	EY1371Q0101B1	front panel	30	VM064005-3	main transformer
7	KE055005	power switch	31	AA055017	rectifier
8	JC055017	ground socket	32	WA055009-3	inductance
9	JC055019	ground plug	33	WB055005-2	balance reactance
10	JA055005	earth clamp	34	EY1371R0103G10	right panel
14	KC081004-A	3 steps switch(coarse)	35	EY1371H0101B1	back panel
15	KC081005-A	10 steps switch (fine)	36	XF055001-1E	power cord
16	EY1371S0101G10	top tray	37	DG055007	power fuse 5A
17	EY1371Z0101B1	inside baffle	38	DG082012-C	power fuse 2A
18	KL055100	relay socket	39	JG063000-E	heating socket
19	KL055110	relay	41	MF055002-2	fan
22	JK055002	terminal board	58	XC055005-2	work return lead
23	RD055022-E	resistor 2W 50Ω	59	BA091000	ammeter
24	VC064005-E	control transformer	60	BA091001	voltmeter
25	KB055009-E	magnetic switch	68	SC074000-E	plastic handle
26	EY1371L0101G10	left panel	69	EY1371W0101B1	handle
27	EY1371X0101B1	bottom board	70	SE055005-2E	gland
28	SG064009	front swivel caster	73	DG084020-2	fuse-holder
29	SG073000	back fixed wheel	74	JG055000	control socket

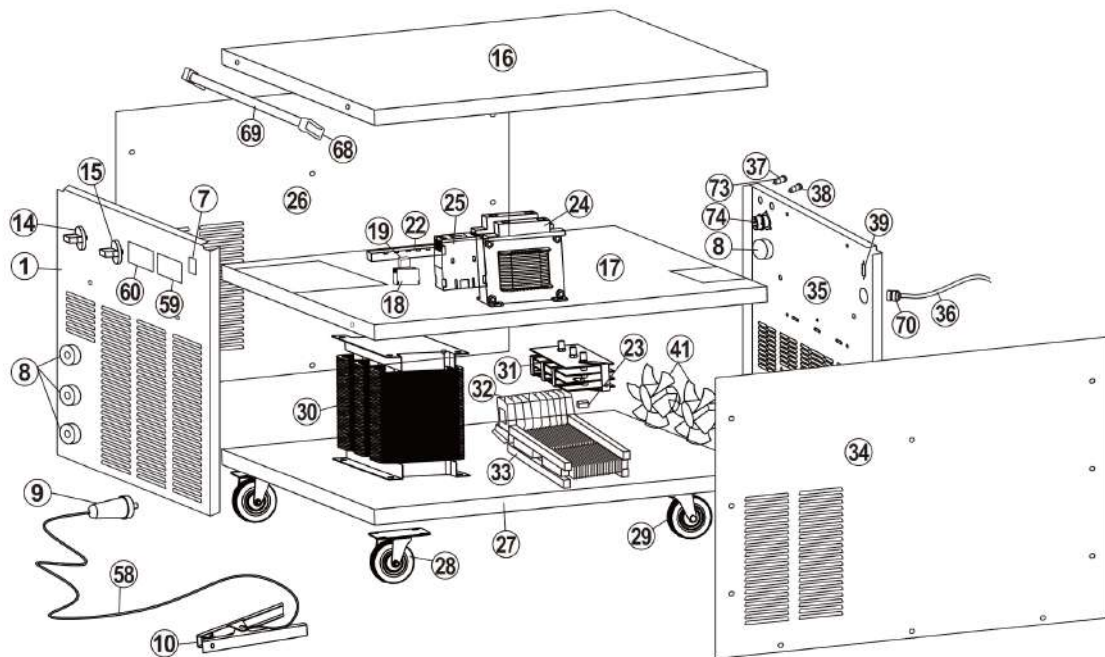



STEADYMIG500

9. Wire Feeder Parts List

NO.	Code	Description	NO.	Code	Description
1	EY1957X0201B1	bottom case	15	JB055005-2	torch connector
2	SE055001-B	knob	16	MC074004-C	wire feeder motor
3	JB055003	torch connector plastic case	17	PA055090-E	wire feeder control circuit board PCB
4	JC062000	water connector	18	SG055011	front swivel caster
5	JC062001	socket for water connector(red)	19	SG055007	back fixed wheel
6	JC062002	socket for water connector(blue)	20	EY1111W0101B1	handle
			21	EY1957H0101B1	back cover
7	JC055016	ground socket	22	EY1957G0101B1	plastic cover motor
			23	ST092132	plastic panel stickers
8	JG055000	control plug	24	JX064001	hinge
9	BF055011-6E-2	solenoid valve	25	SE055010-1	closing
11	EY1957M0102G10	door panel	26	SE082200	plastic panel
12	EY1957Z0101B1	inside baffle			
13	EY1957R0103G10	right panel			
14	SG055009-1	wire support			

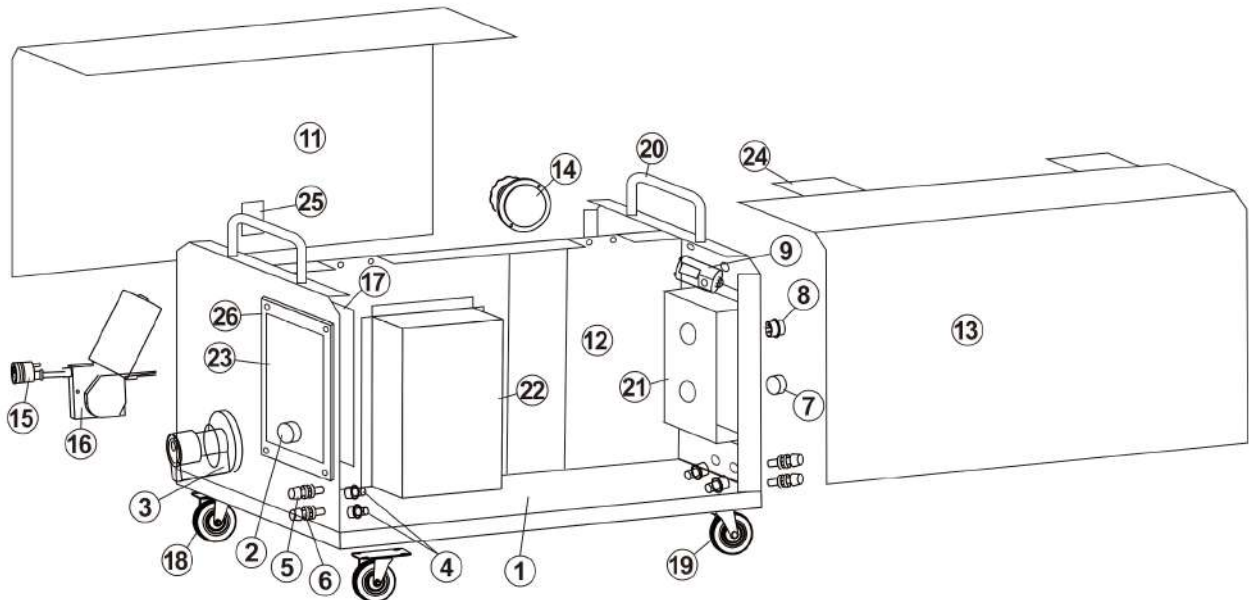



STEADYMIG500

10. Warranty

As part of an on-going commitment to excellence in product support, Euroquip offers a comprehensive product warranty program.

Warranty period for STEADYMIG500:

Commercial Use: 48 Months

Domestic Use: 48 Months

Warranty covers failure caused by manufacturing and material defects in the product, during the warranty period specified. The warranty period begins when the product is purchased by the end user. Warranty is not transferrable and is only claimable by the original purchaser.

Warranty does not cover parts that are subject to wear and tear from usage.

Warranty covers failure of a product caused by defective materials and/or manufacturing for the period given and the usage specified by Euroquip. The warranty period begins when the product is purchased by the end user. Warranty is not transferrable and is only claimable by the original purchaser.

Warranty also does not cover failure caused by the untimely replacement or service of the above wearing parts. Evidence must be provided that the product has been maintained and serviced suitably for a claim to be considered under warranty.

Failure caused by incorrect operation of the product, lack of proper care and maintenance of the product, external damage, external circumstances such as contaminated fuel or poor water supply, modifications to the product, attempted repair/ service by a party other than an Approved Service Agent, is not covered under warranty.

Warranty does not cover pre delivery service and adjustment, or failure that may occur as a result of lack of/ incorrect pre delivery service and adjustment.

Warranty does not cover any incidental, indirect or consequential loss, damage or expense that may result from any defect, failure or malfunction of a product.

Should any issue be found to be a combination of a warranty failure and a non-warranty issue, the repair cost component to rectify and repair the non-warranty failure is the customers' full responsibility.

The decision that an issue with a product qualifies as a warranty claim is made at the sole jurisdiction of Euroquip.

No costs incurred will be considered under warranty if repairs are carried out by a party other than a Euroquip Approved Service Agent, unless with prior consent in writing from Euroquip.

It is the responsibility of the purchaser to deliver a product under warranty to the nearest relevant service agent or product reseller. Warranty does not cover call outs, mileage and freight costs.

If a product is repaired under warranty, parts and labour required for the repair will be supplied at no charge. Warranty assessment and repair will be scheduled and executed according to the normal work flow at the service location and depending on the availability of suitable replacement parts.

This warranty policy is an additional benefit and does not affect the legal rights of any end user, reseller or service agent.



STEADYMIG500



STEADYMIG500



Congratulations on your new STRATA product. We are proud to have you as our customer and will strive to provide you with the best service and reliability in the industry. This product is backed by our extensive warranty. To locate your nearest distributor or service agency visit www.strata.co.nz, or email us at customerservice@euroquip.co.nz

www.strata.co.nz